

# Clarke®



## 400W JIG SAW MODEL NO: CJS400

PART NO: 6462183

## OPERATION & MAINTENANCE INSTRUCTIONS

UK  
CA | CE



ORIGINAL INSTRUCTIONS

GC11/25 - Rev 3

---

## **INTRODUCTION**

---

Thank you for purchasing this CLARKE jigsaw which is designed for DIY use.

When unpacking, check for damage or shortages etc. Any found should be reported to your CLARKE dealer where the saw was originally purchased.

Before attempting to use this product, please read this manual thoroughly and follow the instructions carefully. In doing so you will ensure the safety of yourself and that of others around you, and you can look forward to your purchase giving you long and satisfactory service.

---

## **GUARANTEE**

---

This product is guaranteed against faulty manufacture for a period of 12 months from the date of purchase. Please keep your receipt which will be required as proof of purchase.

This guarantee is invalid if the product is found to have been abused or tampered with in any way, or not used for the purpose for which it was intended.

Faulty goods should be returned to their place of purchase, no product can be returned to us without prior permission.

This guarantee does not effect your statutory rights.

---

## **ENVIRONMENTAL RECYCLING POLICY**

---



By purchasing this product, the customer is taking on the obligation to deal with its safe disposal in accordance with the Waste Electrical and Electronic Equipment (WEEE).

In effect, this means that this product must not be disposed of with general household waste. It must be disposed of according to the laws governing Waste Electrical and Electronic Equipment (WEEE) at a recognised disposal facility.

If disposing of this product or any damaged components, do not dispose of with general waste. This product contains valuable raw materials. Metal products should be taken to your local civic amenity site for recycling of metal products.

---

# GENERAL POWER TOOL SAFETY WARNINGS

---



**WARNING: READ ALL INSTRUCTIONS. FAILURE TO FOLLOW ALL INSTRUCTIONS LISTED BELOW MAY RESULT IN ELECTRIC SHOCK, FIRE AND/OR SERIOUS INJURY. THE TERM "POWER TOOL" IN THE WARNINGS REFERS TO YOUR MAINS-OPERATED JIGSAW.**

---

Save all warnings and instructions for future reference.

## 1) WORK AREA SAFETY

- a. Keep work area clean and well lit. Cluttered or dark areas invite accidents.
- b. **DO NOT** operate power tools in explosive atmospheres, such as in the presence of flammable liquids, gases or dust. Power tools create sparks which may ignite the dust or fumes.
- c. Keep children and bystanders away while operating a power tool. Distractions can cause you to lose control.

## 2) ELECTRICAL SAFETY

- a. Power tool plugs must match the outlet. Never modify the plug in any way. **DO NOT** use any adapter plugs with earthed (grounded) power tools. Unmodified plugs and matching outlets will reduce risk of electric shock.
- b. Avoid body contact with earthed or grounded surfaces, such as pipes, radiators, ranges and refrigerators. There is an increased risk of electric shock if your body is earthed or grounded.
- c. **DO NOT** expose power tools to rain or wet conditions. Water entering a power tool will increase the risk of electric shock.
- d. **DO NOT** abuse the cable. Never use the cable for carrying, pulling or unplugging the power tool. Keep cables away from heat, oil, sharp edges or moving parts. Damaged or entangled cables increase the risk of electric shock.
- e. When operating a power tool outdoors, use an extension cable suitable for outdoor use. Use of a cable suitable for outdoor use reduces the risk of electric shock.
- f. If operating a power tool in a damp location is unavoidable, use a residual current device (RCD) protected supply. Use of an RCD reduces the risk of electric shock.

## 3) PERSONAL SAFETY

- a. Stay alert, watch what you are doing and use common sense when operating a power tool. **DO NOT** use while you are tired or under the influence of drugs, alcohol or medication. A moment of inattention while operating power tools may result in serious personal injury.

- b. Use personal protective equipment. Always wear eye protection. Protective equipment such as dust mask, safety shoes, or hearing protection used for appropriate conditions will reduce personal injuries.
- c. Prevent unintentional starting. Ensure the switch is in the off-position before connecting to power source and/or battery pack, picking up or carrying the tool. Carrying power tools with your finger on the switch or energising power tools that have the switch on invites accidents.
- d. Remove any adjusting key or wrench before turning the power tool on. A wrench or a key left attached to a rotating part of the power tool may result in personal injury.
- e. **DO NOT** overreach. Keep proper footing and balance at all times. This enables better control of the power tool in unexpected situations.
- f. Dress properly. **DO NOT** wear loose clothing or jewellery. Keep hair, clothing and gloves away from moving parts. Loose clothes, jewellery or long hair can be caught in moving parts.
- g. If devices are provided for the connection of dust extraction and collection facilities, ensure these are connected and properly used. Use of dust collection can reduce dust-related hazards.

#### **4) POWER TOOL USE AND CARE**

- a. **DO NOT** force the power tool. Use the correct power tool for your application. The correct power tool will do the job better and safer at the rate for which it was designed.
- b. **DO NOT** use the power tool if the switch does not turn it on and off. Any power tool that cannot be controlled with the switch is dangerous and must be repaired.
- c. Disconnect the plug from the power source and/or the battery pack from the power tool before making any adjustments, changing accessories, or storing power tools. Such preventive safety measures reduce the risk of starting the power tool accidentally.
- d. Store idle power tools out of the reach of children and do not allow persons unfamiliar with the tool or these instructions to operate the power tool. Power tools are dangerous in the hands of untrained users.
- e. Maintain power tools. Check for misalignment or binding of moving parts, breakage of parts and any other condition that may affect the power tool's operation. If damaged, have the power tool repaired before use. Many accidents are caused by poorly maintained tools.
- f. Keep cutting tools sharp and clean. Properly maintained cutting tools with sharp cutting edges are less likely to bind and are easier to control.
- g. Use the power tool, accessories and tool bits etc. in accordance with these instructions, taking into account the working conditions and the work to be

performed. Use of the power tool for operations different from those intended could result in a hazardous situation.

## 5) SERVICING

- a. Have your power tool serviced by a qualified repair person using only identical replacement parts to ensure that the safety of the power tool is maintained.

---

## SPECIFIC WARNINGS FOR JIGSAWS

---

1. **ONLY** sharp saw blades in perfect working condition should be used; cracked or bent saw blades should be discarded and replaced at once.
2. **ALWAYS** ensure that the blade is securely fixed.
3. **ALWAYS** use the appropriate blade for the material being cut.
4. **ALWAYS** use a cooling agent when cutting metals, i.e. cutting oil.
5. **ALWAYS** allow sufficient clearance beneath the work to ensure the blade does not come into contact with the floor, table etc.
6. **ALWAYS** check for hidden electrical wires or water pipes etc.
7. **ALWAYS** keep the mains cable well away from the machine and ensure an adequate electrical supply is close at hand so that the operation is not restricted by the length of the cable.
8. When cutting wood, ensure any nails have been removed beforehand. Nails will damage the wood saw blade.
9. **NEVER** allow the ventilation slots in the machine to become blocked.
10. **NEVER** attempt to stop the saw blade with your fingers.
11. **NEVER** put the saw down on a table or work bench unless switched off. The saw blade will keep running briefly after the tool has been switched off.
12. **DO NOT** cut material above the specified thickness.
13. **DO NOT** cut through walls or cavities before checking for hidden electrical wires or water pipes etc.
14. **DO NOT** touch the blade immediately after use, allow time for it to cool.
15. **DO NOT** attempt to saw extremely small workpieces.
16. Wherever possible, use clamps and vices to fasten the workpiece securely.

# ELECTRICAL CONNECTIONS



**WARNING: READ THESE ELECTRICAL SAFETY INSTRUCTIONS THOROUGHLY BEFORE CONNECTING THE PRODUCT TO THE MAINS SUPPLY.**

This product is provided with a standard BS 1363 plug, for connection to a standard, domestic electrical supply. Should the plug need changing at any time, ensure that a plug of identical specification is used.



**WARNING: THE WIRES IN THE POWER CABLE OF THIS PRODUCT ARE COLOURED IN ACCORDANCE WITH THE FOLLOWING CODE:  
BLUE = NEUTRAL    BROWN = LIVE**

If the colours of the wires in the power cable of this product do not correspond with the markings on the terminals of your plug, proceed as follows.

- The **Blue** wire must be connected to the terminal marked **N** or coloured **Black**.
- The **Brown** wire must be connected to the terminal marked **L** or coloured **Red**.

Plug must be BS1363/A approved.

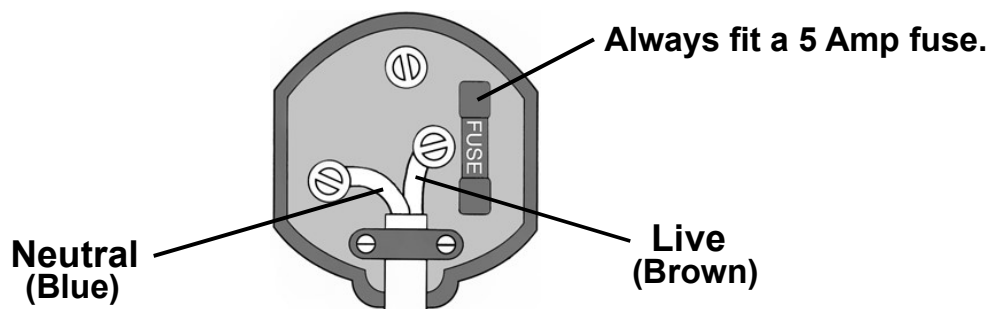

Ensure that the outer sheath of the cable is firmly held by the clamp

**We strongly recommend that this machine is connected to the mains supply via a Residual Current Device (RCD)**

If in any doubt, consult a qualified electrician. **DO NOT** attempt any repairs yourself.



**This symbol indicates that this is a Class II product and does not require an earth connection.**

## OVERVIEW

The CLARKE CJS400 is a 400W variable-speed jigsaw fitted with a lock-on button for continuous operation. It is designed with a dust extract port for connection to a vacuum system and is supplied with 1.8 metres of cable with plug. The jigsaw is equipped with a T-shank SDS type quick-release (twist lock) blade retention system for convenient replacement of saw blades.

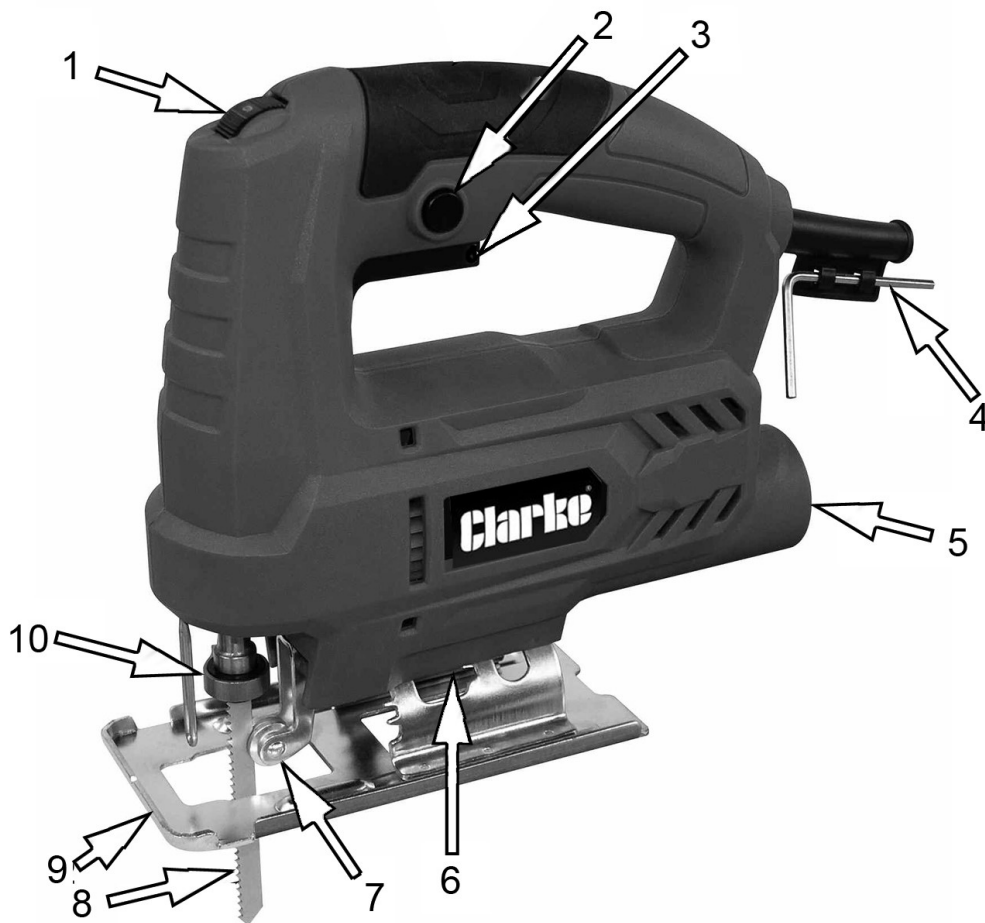

1	Speed control	6	Base adjusting screws
2	Lock-on button	7	Blade support roller
3	On/off trigger switch	8	Blade
4	Hex key/holder	9	Sole plate
5	Dust extraction port	10	Blade retainer

---

## INSTALLING/CHANGING BLADES

---

1. Use only jigsaw blades with the correcting T-shank.
  2. This jigsaw comes with a convenient tool-less quick release blade retainer. To install a blade, use your thumb to pull the lever counter-clockwise to open the blade retainer (A).
  3. With the blade teeth facing forward, insert the blade (B) into the blade retainer as far as it will go. Make sure that the back edge of the blade sits against the blade support roller (C). Move the spring-loaded lever (A) to insert the blade, then pull on the blade until the blade retainer snaps shut and secures the blade.
- Take care never to use cracked, blunt or damaged blades.

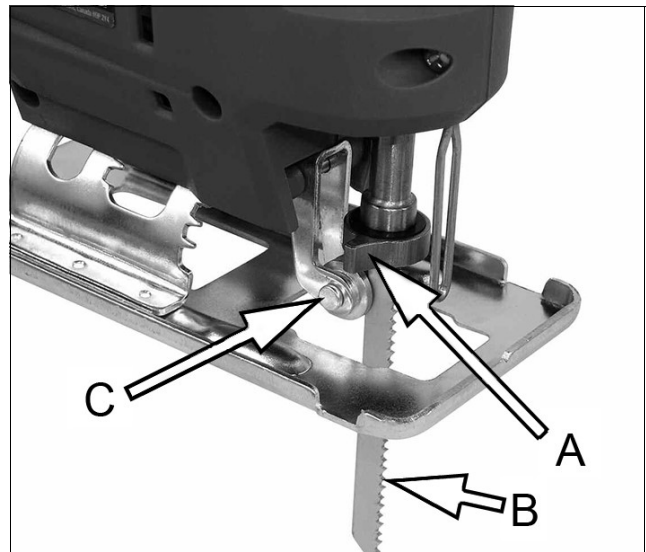

---

## OPERATION

---



CAUTION: DO NOT PLUG INTO THE MAINS UNLESS YOU HAVE ENSURED THE JIGSAW IS SWITCHED OFF. TO DO THIS, SQUEEZE THE TRIGGER FULLY UPWARDS, THEN RELEASE IT. THE TRIGGER IS LOCATED UNDER THE GRIP.

---

## TURNING ON AND OFF

1. To start the jigsaw, squeeze the trigger (B). Wait until the blade is running at speed before attempting to cut the workpiece.

## CONTINUOUS OPERATION

1. Maintain the saw at constant speed by pressing in the lock-on button (A).
  - You can then release your finger pressure on the trigger (B).
2. To stop the jigsaw if the lock-on button is used, squeeze the trigger fully in, then release it and the motor will stop.



## ADJUSTING THE SPEED

The jigsaw speed can be adjusted between 0 and 3,000 strokes per minute by turning the speed selector (A).

- The selector is marked 1 (lowest speed) to 6 (full speed).

In general, higher speeds will allow you to cut workpieces faster but the service life of the blade will be reduced.



## DUST COLLECTION

The jigsaw is provided with a dust extract connection, (A) where a vacuum extractor may be connected to the rear of the machine.

Please note however, that this does not preclude the user from wearing a face mask to prevent the inhalation of dust particles.

Connect the vacuum extractor port to an extract system wherever possible.

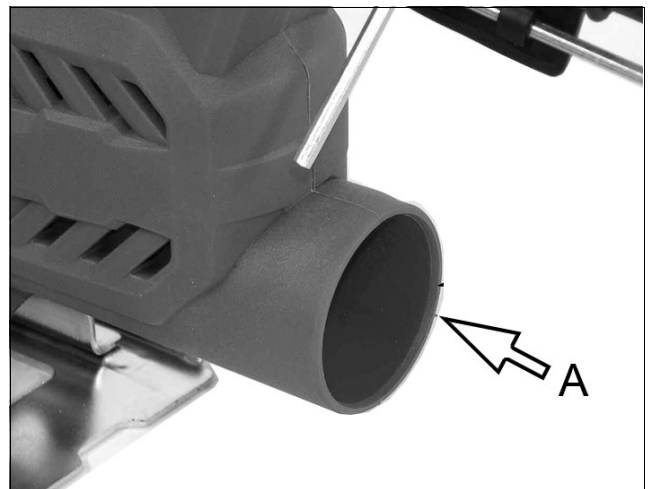

## ADJUSTING THE SOLE PLATE FOR BEVEL CUTTING

The sole-plate (A) can be tilted so that bevels of up to 45° may be cut (left or right).

1. Loosen the two socket head screws (B) under the body of the saw using the hex key supplied, before tilting the sole plate to the desired angle and re-tightening the screws.
2. Use the angle marks (C) as a guide to the angle achieved. The marks indicate the tilt angle from 0 to 45 degrees.

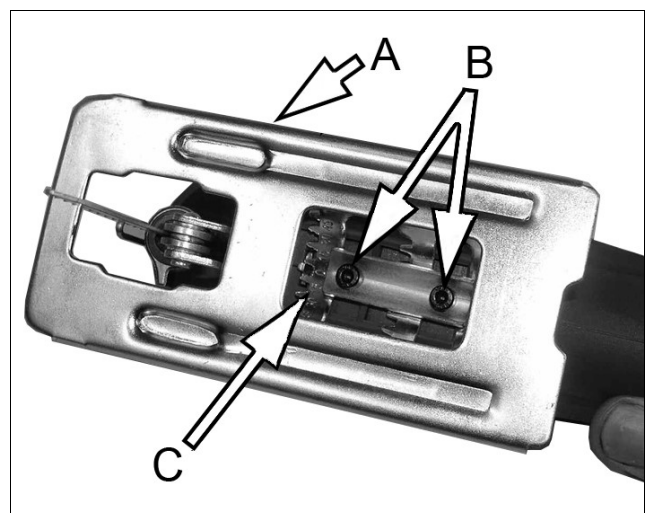

---

# CUTTING PROCEDURES

---



**WARNING: IF THE CUTTING OPERATION IS DUSTY, WE RECOMMEND THAT YOU WEAR A DUST MASK.**

---

## USING THE JIGSAW

1. Ensure that the workpiece being cut is securely held in place and that the cut line is clearly marked.
2. Place the sole-plate on the workpiece and squeeze the trigger to run the jigsaw up to its working speed before letting the blade touch the cut line.
3. To make your cut, move the saw slowly forward along the cutting line taking care that the blade is vertical (unless making an angled cut) and correctly positioned in relation to the cut line.
4. Let the blade work forward, ensuring the sole plate is flush with the workpiece.
5. **DO NOT** press too hard. If the saw slows down as it is cutting, apply less pressure.
6. Adjust the speed control to suit the material being cut. The optimum speed will be determined with practice.
7. When sawing do not put unnecessary pressure on the blade and avoid applying lateral pressure.
8. Take extra care when cutting curves - move the blade slowly to avoid stress on the blade.
9. Check that any previously used timber being sawn does not contain any nails or other metal objects which would damage the blade.
10. Ensure the blade is not striking on anything below the workpiece and that the power cable is well away from the moving blade before starting the saw.
  - If cutting out an aperture, it will be necessary to drill a suitably sized hole in the workpiece for use as a starting point.
  - Note that the blade should emerge from the workpiece at every point of the cut.
11. Allow the saw to come to a complete stop before putting it down.
12. To prevent accidents, turn off the saw and disconnect the power supply after use. Clean, then store the saw indoors out of the reach of children.

---

# MAINTENANCE AND SERVICING

---



**WARNING: BEFORE PERFORMING ANY MAINTENANCE TASKS  
ENSURE THE PLUG HAS BEEN REMOVED FROM THE MAINS SUPPLY.**

---

## GENERAL MAINTENANCE

1. Check that the power cable is free from cracks, bare wires etc. Avoid using solvents when cleaning plastic parts. Most plastics are susceptible to damage from solvents.
2. Ensure all screws remain tight to ensure the jigsaw is in safe working condition.
  - All bearings etc, in this machine are lubricated with a sufficient amount of high grade lubricant for the tools lifetime under normal operating conditions, therefore no further lubrication is required.
  - Only use the replacement blades specified for this product available from your CLARKE dealer.
3. After use, clean all dust and wood dust from the saw. To ensure constant air circulation, always keep air vents clear of blockages, (use compressed air to clean the machine if possible. (Wear PPE when using compressed air).
4. Keep the sole plate free from dirt and grime. Regularly clean to prevent scratches and scores on the surface.
5. Resin and glue on the blade causes poor cutting results. If necessary clean the blade after use.
6. Refer to your CLARKE dealer if internal maintenance is required.

## REPLACEMENT BLADES

Replacement blades are available from your CLARKE dealer as follows:

Wood - 6462196 (pack of 5)

Metal - 6462198 (pack of 5)

## TROUBLESHOOTING

<b>Problem</b>	<b>Cause</b>	<b>Solution</b>
Jigsaw does not operate	Damaged cable or fuse.	Inspect and have repaired or replaced.
Blade jams, binds or burns the wood	Wrong blade for the material. Blade is worn out Incorrect operation	Use correct blade for the material being cut. Replace blade. Refer to Cutting Procedures on page 10
Motor overheats	Motor air vents blocked	Clean jigsaw see page 11.
Blade cannot be fitted or removed	Blade clamp blocked with compacted dust	Clean clamp with brush and/or compressed air

## PARTS LIST

1	Left housing	18	Rack
2	Variable speed selector	19	Washer
3	Switch	20	Bearing
4	Carbon brush cover	21	Large gear
5	Carbon brush holder	22	Drive peg
6	Carbon brush	23	Balance board
7	Cable clamp	24	Blade holder/shank
8	Screw	25	Blade
9	Cable gland	26	Blade guard
10	Allen key	27	Angle adjusting boards
11	Power cable	28	Sole plate holder
12	Inductor	29	Allen screw
13	Stator	30	Support roller assembly
14	Bearing 626	31	Pin
15	Rotor	32	Screw
16	Bearing 608	33	Right housing
17	Fibre washer	34	Sole plate

# PARTS DIAGRAM

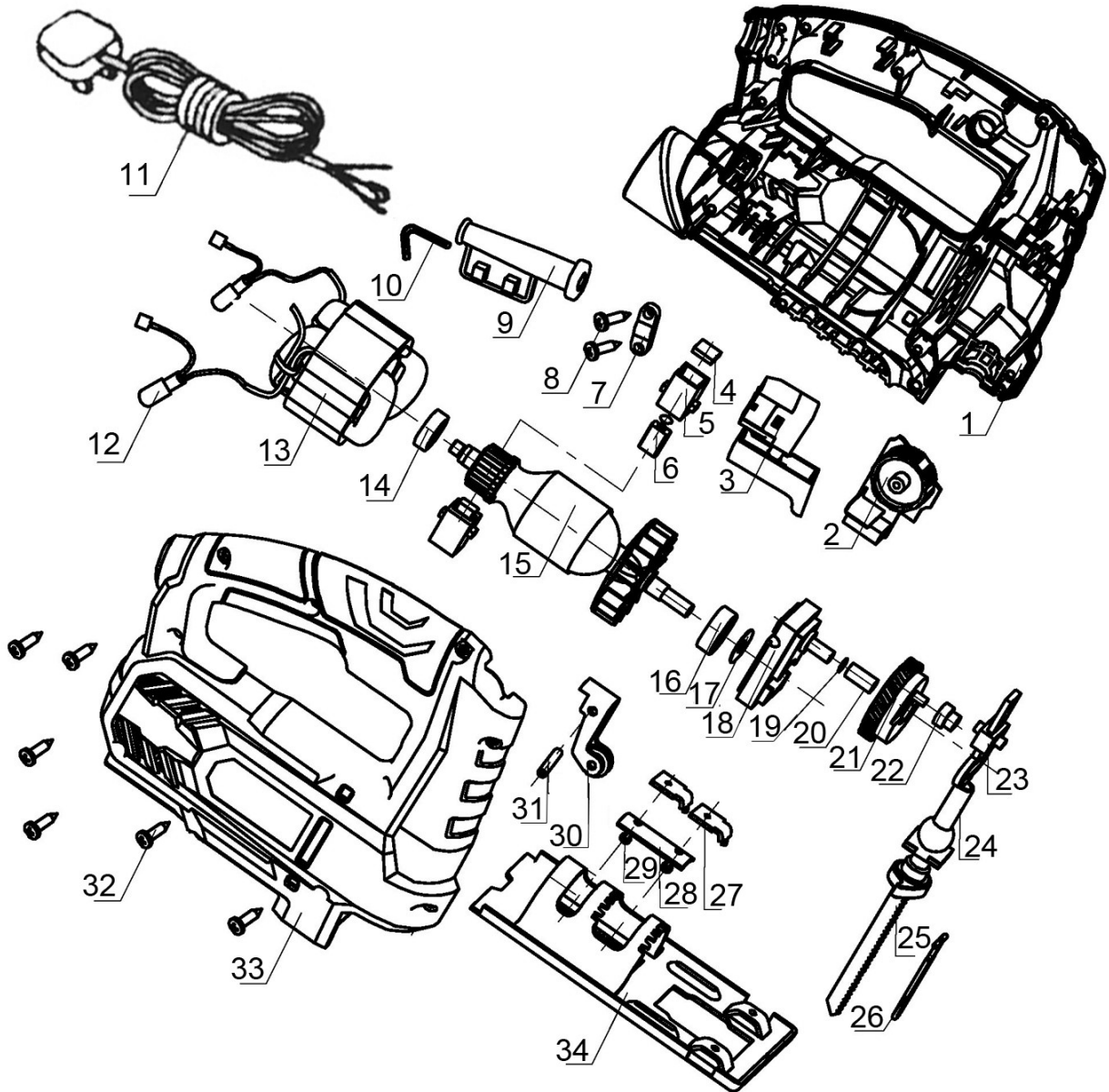

---

# SPECIFICATIONS

---

---

## MODEL CJS400

---

Voltage	230 V AC @ 50Hz
Input power	400 Watts
Input current	1.79 A
Ingress protection rating	IPX0
Insulation class	II
Duty cycle	S1 (continuous)
No-load speed	0–3000 strokes per min
Weight	1.56 kg
Dimensions (L x H x W)	250 x 200 x 68 mm
Max cutting depth	55 mm at 90° 35 mm at 45°
Cutting angles	0°, 15°, 30° & 45° (left and right)
Blade type	SDS blades 100mm x 30 teeth
Note: product only supplied with single wood blade only	See page 11 for CLARKE part numbers
Dust extraction port size	35/39.9 mm dia
Sound Pressure Level (LPA)	88.7 dB(A)
Sound Power Level (LWA)	99.7 dB(A)
Sound Uncertainty Value (K)	3 dB(A)
Vibration	13.521 m/s <sup>2</sup>
Vibration Uncertainty Value (K)	1.5 m/s <sup>2</sup>

---

# DECLARATION OF CONFORMITY



Hemncill Street, Epping, Essex CM16 4JG

## DECLARATION OF CONFORMITY

This is an important document and should be retained.

We hereby declare that this product(s) complies with the following statutory requirement(s):

- Electromagnetic Compatibility Regulations 2016*
- Supply of Machinery (Safety) Regulations 2008*
- The Restriction of the Use of Certain Hazardous Substances in Electrical and Electronic Equipment Regulations 2012*

The following standards have been applied to the product(s):

- EN 55014-1:2017, EN 55014-2:2015, EN IEC 61000-3-2:2019, EN 61000-3-3:2013 + A1,
- EN 62841-1:2015, EN 62841-2-11:2016, IEC 62321-1:2013, IEC 62321-2:2013,
- IEC 62321-3-1:2013, IEC 62321-4:2013 + AMD1:2017 CSV, IEC 62321-5:2013, IEC 62321-6:2015,
- IEC 62321-7-1:2015, IEC 62321-7-2:2017, IEC 62321-8:2017, ISO 17075:2017.

The technical documentation required to demonstrate that the product(s) meet(s) the requirement(s) of the aforementioned legislation has been compiled and is available for inspection by the relevant enforcement authorities.

The UKCA mark was first applied in: 2022

Product Description: 400W Variable Speed Jigsaw  
Model number(s): CJS400  
Serial / batch Number: N/A  
Date of issue: 19/10/2022

Signed:

J.A. Clarke  
Director

CJS400 UKCA Clarke DOC 101922

Page 1 of 1



Fitzwilliam Hall, Fitzwilliam Place, Dublin 2

## DECLARATION OF CONFORMITY

This is an important document and should be retained.

We hereby declare that this product(s) complies with the following directive(s):

- 2014/30/EU *Electromagnetic Compatibility Directive*
- 2006/42/EC *Machinery Directive*
- 2011/65/EU *Restriction of the Use of Certain Hazardous Substances in Electrical & Electronic Equipment (RoHS) Directive*

The following standards have been applied to the product(s):

- EN 55014-1:2017, EN 55014-2:2015, EN IEC 61000-3-2:2019, EN 61000-3-3:2013 + A1,
- EN 62841-1:2015, EN 62841-2-11:2016, IEC 62321-1:2013, IEC 62321-2:2013,
- IEC 62321-3-1:2013, IEC 62321-4:2013 + AMD1:2017 CSV, IEC 62321-5:2013, IEC 62321-6:2015,
- IEC 62321-7-1:2015, IEC 62321-7-2:2017, IEC 62321-8:2017, ISO 17075:2017.

The technical documentation required to demonstrate that the product(s) meet(s) the requirement(s) of the aforementioned directive(s) has been compiled and is available for inspection by the relevant enforcement authorities.

The CE mark was first applied in: 2020

Product Description: 400W Variable Speed Jigsaw  
Model number(s): CJS400  
Serial / batch Number: N/A  
Date of issue: 19/10/2022

Signed:

J.A. Clarke  
Director

CJS400 CE Clarke DOC 101922

Page 1 of 1

# A SELECTION FROM THE VAST RANGE OF

# Clarke®

## QUALITY PRODUCTS



**AIR COMPRESSORS**  
From DIY to industrial, Plus air tools, spray guns and accessories.

**GENERATORS**  
Prime duty or emergency standby for business, home and leisure.

**POWER WASHERS**  
Hot and cold, electric and engine driven - we have what you need

**WELDERS**  
Mig, Arc, Tig and Spot. From DIY to auto/industrial.

**METALWORKING**  
Drills, grinders and saws for DIY and professional use.

**WOODWORKING**  
Saws, sanders, lathes, mortisers and dust extraction.

**HYDRAULICS**  
Cranes, body repair kits, transmission jacks for all types of workshop use.

**WATER PUMPS**  
Submersible, electric and engine driven for DIY, agriculture and industry.

**POWERTOOLS**  
Angle grinders, cordless drill sets, saws and sanders.

**STARTERS/CHARGERS**  
All sizes for car and commercial use.



## PARTS & SERVICE: 0208 988 7400

**Parts Enquiries**  
[Parts@clarkeinternational.com](mailto:Parts@clarkeinternational.com)

**Servicing & Technical Enquiries**  
[Service@clarkeinternational.com](mailto:Service@clarkeinternational.com)

SALES: UK 01992 565333 or Export 00 44 (0)1992 565335

**Clarke** INTERNATIONAL Hemnall Street, Epping, Essex CM16 4LG  
[www.clarkeinternational.com](http://www.clarkeinternational.com)